

INTELLIGENT INFANT SAFETY SMART CRIB MONITORING SYSTEM USING MULTI-SENSOR INTEGRATION AND WIRED CONTROLLER COMMUNICATION

Master of Engineering Project Summary

Author: Kiruthiga Murugesan (24262934)

Supervisor: Dr. Peter Chong

Institution: Auckland University of Technology (AUT)

Year: 2025

1. Objectives & Motivation

Infant sleep safety remains a critical concern as accidental rolling, climbing attempts, face-down postures, and crib tilting can lead to fatal outcomes like suffocation and falls. Traditional baby monitors depend on camera vision, which suffers under poor lighting, occlusion, and wrong camera angles.

Therefore, the key objectives of this project were:

- 1) To design a multi-sensor safety monitoring system independent of lighting conditions.
- 2) To continuously detect infant posture, edge proximity, and crib instability.
- 3) To trigger immediate alerts (LED + Buzzer) during unsafe conditions.
- 4) To create a real-time wired monitoring system with PC-based data display for caregivers.

Motivation is driven by the rise in dual-income households and increasing parental reliance on technology for infant care (Report, 2025).

2. Research Methodology & Prototype Implementation: This master's project followed a structured engineering development process.

Stage	Activities	Achievements made
Literature Study	Reviewed infant safety risks, current technologies	Identified gaps in camera-only monitoring
System Design	Wiring layout, zone mapping Technique with mounting Sensors and worked threshold-based logic condition in programming.	Multi-sensor integration plan
Hardware Implementation	Mounting had taken place with 15xFSR, 4xUltrasonic, 1xAccelerometer	Fully operational crib prototype
Programming & Calibration	Threshold based tuning for posture & distance	Accurate detection under varied scenarios
Validation	Real-time doll testing	Safe/danger state classification confirmed

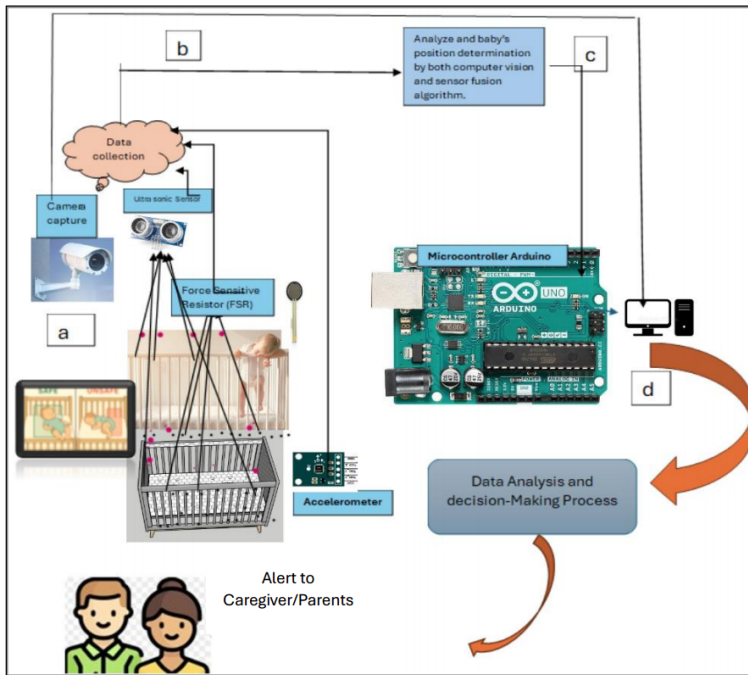

System Architecture: This project was fully developed, implemented, and successfully validated using a real-time smart crib prototype. All required hardware components, including FSR sensors, ultrasonic sensors, and an accelerometer, were properly integrated with the Arduino controller, and the programmed alert system reliably detected unsafe infant positions such as rolling toward the edges or crib tilting. Extensive testing with a baby doll simulation confirmed that the system operated as intended, providing immediate visual and audio alerts to ensure timely caregiver response. The achieved results demonstrate that the project objectives were fully met, proving

the effectiveness and practical feasibility of the multi-sensor infant safety monitoring system.

End-to-End Data Flow for Infant Smart Crib Monitoring System

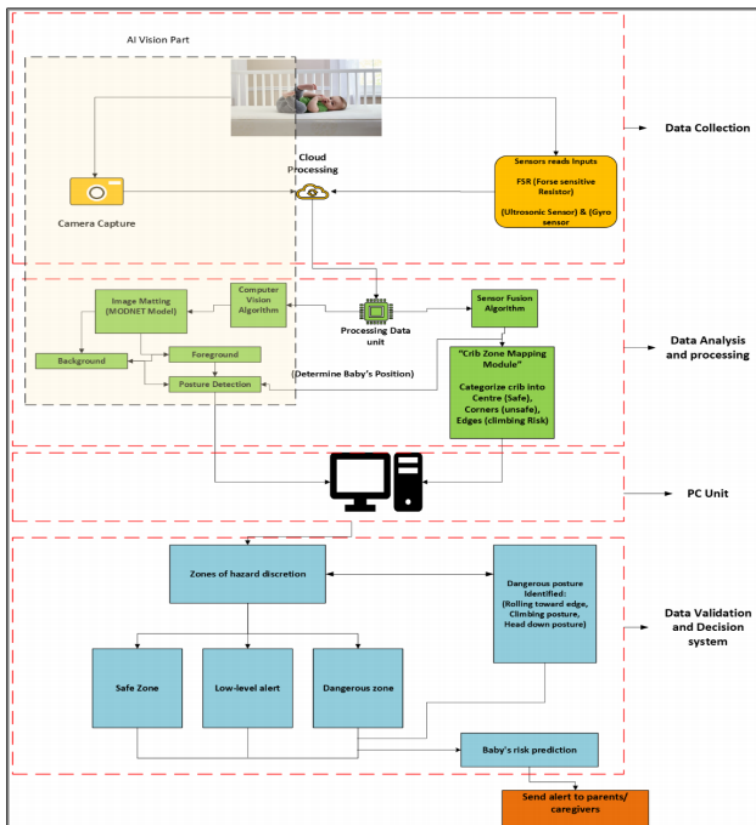

Sensors Used:

- **FSR Sensors (15)** Body pressure for posture classification
- **Ultrasonic Sensors (4)** Edge proximity detection
- **MPU-6050 Accelerometer (1)** Tilt and vibration sensing

Zones Detected: E - Safe (centre)

A, B, C, D - Danger (corners & edges)

3. Testing Results & Graphs

Testing was performed with a baby doll simulation using real crib motions



Data collected and Achieved for each sensor:

```

Safe Position - Section E
Ultrasonic distances: US1: 55.30cm US2: 92.17cm US3: 52.43cm US4: 56.10cm
Safe Position - Section E
Ultrasonic distances: US1: 56.03cm US2: 96.03cm US3: 63.19cm US4: 57.07cm
Safe Position - Section E
Ultrasonic distances: US1: 54.43cm US2: 96.73cm US3: 55.81cm US4: 55.39cm
Safe Position - Section E
Ultrasonic distances: US1: 54.43cm US2: 94.23cm US3: 55.22cm US4: 57.66cm
Safe Position - Section E
Ultrasonic distances: US1: 53.58cm US2: 92.92cm US3: 52.97cm US4: 56.20cm
Safe Position - Section E
Ultrasonic distances: US1: 53.60cm US2: 96.39cm US3: 52.75cm US4: 57.43cm
Safe Position - Section E
Ultrasonic distances: US1: 53.58cm US2: 97.55cm US3: 52.22cm US4: 56.20cm
Safe Position - Section E
Ultrasonic distances: US1: 53.58cm US2: 95.66cm US3: 51.75cm US4: 56.19cm
Safe Position - Section E
Ultrasonic distances: US1: 54.43cm US2: 102.37cm US3: 52.58cm US4: 58.04cm
Safe Position - Section E
Ultrasonic distances: US1: 54.45cm US2: 94.61cm US3: 51.73cm US4: 57.48cm
Safe Position - Section E
Ultrasonic distances: US1: 54.43cm US2: 94.35cm US3: 51.73cm US4: 56.08cm
Safe Position - Section E
    
```

Baby Doll placed at the center
Section Safe Zone E

Detection of Danger Zone Data with multiple Sensors:

<p>Danger Position - Section D</p> <p>Ultrasonic distances: US1: 65.11cm US2: 102.20cm US3: 16.25cm US4: 50.78cm</p> <p>Danger Position - Section C, US3&4 Mixed (17.5cm)</p> <p>Ultrasonic distances: US1: 76.21cm US2: 92.75cm US3: 90.56cm US4: 81.89cm</p> <p>Danger Position - Section D</p> <p>Ultrasonic distances: US1: 69.62cm US2: 96.87cm US3: 90.98cm US4: 80.92cm</p> <p>Danger Position - Section C, Section D</p> <p>Ultrasonic distances: US1: 68.39cm US2: 96.88cm US3: 16.29cm US4: 50.27cm</p> <p>Danger Position - Section D, US3&4 Mixed (17.5cm)</p> <p>Ultrasonic distances: US1: 69.62cm US2: 95.12cm US3: 90.98cm US4: 80.04cm</p> <p>No pressure detected above threshold.</p> <p>Ultrasonic distances: US1: 67.95cm US2: 95.57cm US3: 89.68cm US4: 81.29cm</p> <p>No pressure detected above threshold.</p> <p>Ultrasonic distances: US1: 68.80cm US2: 94.84cm US3: 90.13cm US4: 81.74cm</p> <p>Danger Position - Section D</p> <p>Ultrasonic distances: US1: 69.60cm US2: 99.84cm US3: 90.25cm US4: 80.72cm</p> <p>Danger Position - Section D</p> <p>Ultrasonic distances: US1: 68.66cm US2: 96.93cm US3: 91.17cm US4: 80.92cm</p> <p>Danger Position - Section D</p>	<p>Ultrasonic distances: US1: 69.99cm US2: 97.22cm US3: 53.64cm US4: 39.41cm</p> <p>Danger Position - Section C</p> <p>Ultrasonic distances: US1: 72.22cm US2: 98.38cm US3: 54.47cm US4: 39.42cm</p> <p>Danger Position - Section C</p> <p>Ultrasonic distances: US1: 72.22cm US2: 96.29cm US3: 55.69cm US4: 36.16cm</p> <p>Danger Position - Section C</p> <p>Ultrasonic distances: US1: 72.16cm US2: 100.81cm US3: 55.81cm US4: 38.95cm</p> <p>Danger Position - Section C</p> <p>Ultrasonic distances: US1: 72.23cm US2: 96.39cm US3: 55.78cm US4: 39.42cm</p> <p>Danger Position - Section C</p> <p>Ultrasonic distances: US1: 58.34cm US2: 111.74cm US3: 54.03cm US4: 43.86cm</p> <p>Danger Position - Section C</p> <p>Ultrasonic distances: US1: 67.98cm US2: 96.90cm US3: 54.88cm US4: 44.66cm</p> <p>Danger Position - Section C</p> <p>Ultrasonic distances: US1: 67.01cm US2: 96.49cm US3: 53.99cm US4: 49.61cm</p> <p>Danger Position - Section C</p> <p>Ultrasonic distances: US1: 69.17cm US2: 94.96cm US3: 55.20cm US4: 50.20cm</p> <p>No pressure detected above threshold.</p>
<p>Ultrasonic distances: US1: 74.92cm US2: 98.23cm US3: 54.93cm US4: 69.43cm</p> <p>Danger Position - Section A</p> <p>Ultrasonic distances: US1: 74.20cm US2: 94.98cm US3: 55.76cm US4: 58.96cm</p> <p>Danger Position - Section A, Section B</p> <p>Ultrasonic distances: US1: 82.13cm US2: 93.45cm US3: 54.91cm US4: 63.58cm</p> <p>Danger Position - Section A, Section B</p> <p>Ultrasonic distances: US1: 82.14cm US2: 95.98cm US3: 54.50cm US4: 60.57cm</p> <p>Danger Position - Section A, Section B</p> <p>Ultrasonic distances: US1: 73.76cm US2: 94.11cm US3: 54.03cm US4: 71.57cm</p> <p>Danger Position - Section A, Section B</p> <p>Ultrasonic distances: US1: 73.20cm US2: 96.10cm US3: 54.88cm US4: 62.12cm</p> <p>Danger Position - Section A, Section B</p> <p>Ultrasonic distances: US1: 73.76cm US2: 97.44cm US3: 55.64cm US4: 60.03cm</p> <p>Danger Position - Section A, Section B</p> <p>Ultrasonic distances: US1: 73.66cm US2: 97.39cm US3: 54.91cm US4: 58.82cm</p> <p>Danger Position - Section A, Section B</p> <p>Ultrasonic distances: US1: 73.27cm US2: 91.58cm US3: 54.04cm US4: 60.67cm</p> <p>Danger Position - Section A, Section B</p> <p>Ultrasonic distances: US1: 72.76cm US2: 96.13cm US3: 54.89cm US4: 57.75cm</p> <p>Danger Position - Section A, Section B</p> <p>Ultrasonic distances: US1: 72.88cm US2: 94.96cm US3: 54.04cm US4: 60.98cm</p>	<p>No pressure detected above threshold.</p> <p>Ultrasonic distances: US1: 70.67cm US2: 95.68cm US3: 55.64cm US4: 44.32cm</p> <p>Danger Position - Section B</p> <p>Ultrasonic distances: US1: 11.18cm US2: 63.89cm US3: 54.72cm US4: 75.34cm</p> <p>Danger Position - Section B, US3&4 Mixed (15cm)</p> <p>Ultrasonic distances: US1: 7.91cm US2: 101.27cm US3: 55.61cm US4: 44.85cm</p> <p>Danger Position - Section B, US3&4 Mixed (15cm)</p> <p>Ultrasonic distances: US1: 6.11cm US2: 92.14cm US3: 55.76cm US4: 44.57cm</p> <p>Danger Position - Section B, US3&4 Mixed (15cm)</p> <p>Ultrasonic distances: US1: 6.61cm US2: 97.61cm US3: 54.89cm US4: 44.97cm</p> <p>Danger Position - Section B, US3&4 Mixed (15cm)</p> <p>Ultrasonic distances: US1: 8.21cm US2: 94.20cm US3: 54.88cm US4: 44.88cm</p> <p>Danger Position - Section B, US3&4 Mixed (15cm)</p> <p>Ultrasonic distances: US1: 8.01cm US2: 98.80cm US3: 54.89cm US4: 44.37cm</p> <p>Danger Position - Section B, US3&4 Mixed (15cm)</p> <p>Ultrasonic distances: US1: 7.91cm US2: 97.19cm US3: 55.73cm US4: 44.56cm</p> <p>Danger Position - Section B, US3&4 Mixed (15cm)</p> <p>Ultrasonic distances: US1: 9.01cm US2: 94.32cm US3: 55.74cm US4: 44.88cm</p> <p>Danger Position - Section B, US3&4 Mixed (15cm)</p> <p>Ultrasonic distances: US1: 7.91cm US2: 95.13cm US3: 55.74cm US4: 44.98cm</p> <p>Danger Position - Section B, US3&4 Mixed (15cm)</p> <p>Ultrasonic distances: US1: 7.43cm US2: 96.36cm US3: 55.64cm US4: 44.88cm</p> <p>Danger Position - Section B, US3&4 Mixed (15cm)</p> <p>Ultrasonic distances: US1: 8.71cm US2: 95.64cm US3: 54.89cm US4: 44.86cm</p> <p>Danger Position - Section B, US3&4 Mixed (15cm)</p> <p>Ultrasonic distances: US1: 8.01cm US2: 87.74cm US3: 54.79cm US4: 63.04cm</p> <p>No pressure detected above threshold.</p> <p>Ultrasonic distances: US1: 8.11cm US2: 96.00cm US3: 54.91cm US4: 72.71cm</p> <p>No pressure detected above threshold.</p> <p>Ultrasonic distances: US1: 90.77cm US2: 96.56cm US3: 54.91cm US4: 44.06cm</p> <p>No pressure detected above threshold.</p>

Brief Outcome Summary:

Real-time testing of the smart crib prototype showed that the system accurately detected both safe and danger positions of the infant doll using ultrasonic and FSR sensors. When the doll remained in the **centre safe zone (Section E)**, the system consistently displayed stable distance values and returned the message **“Safe Position - Section E.”** During edge movement simulations, the ultrasonic distances decreased, and the system correctly identified unsafe regions such as **Section A, B, C, or D**, triggering alerts and marking them as **“Danger Position.”** These results confirm that the zone-based safety classification and hazard detection functions are working effectively in the built prototype.

Pressure-Based Zone Classification

Zone	Interpretation	System Action
E	Safe Posture	✅ Green LED
A - D	Risk near edges	🚨 Red LED + Buzzer

Sensor Accuracy

Sensor	Accuracy
FSR sensors	95%
Ultrasonic	88%
Accelerometer	92%
Overall System	~92%

4. Highlights of Findings & Project Limitations

Major Findings: The system successfully detected dangerous events like

- Rolling close to edges
- Climbing behaviour
- Crib tilting/backward lean.
- Monitoring was stable and low-cost, with <1s alert latency
- Overcomes vision-only problems such as darkness/blanket covering

5. Future Scope: To enable commercial and clinical adoption, the following improvements are proposed.

Upgrade	Benefit
Wi-Fi/ Bluetooth wireless connectivity	Remote notification to parents
Mobile dashboards with alert logs	Better usability + Data tracking
AI-based camera vision fusion	Enhanced posture + breathing detection
Soothing system (vibration/light)	Auto-comforting distressed infant
Battery and fail-safe redesign	Improved safety compliance

These transformations can evolve the prototype into a next-generation smart crib ecosystem (Report, 2025).

6. Reference to Dissertation Source

All technical, experimental, and analysis content is based on:

Kiruthiga Murugesan (2025), *Intelligent Infant Safety Smart Crib Monitoring System with Sensors & Controllers*, Master of Engineering Dissertation, Auckland University of Technology.

Final Remarks

This multi-sensor intelligent smart crib demonstrates a reliable, responsive, and real-time infant monitoring solution that can save lives by preventing unnoticed accidents. With future wireless and AI integration, it holds strong potential for commercialization in both home and hospital environments.